

Review on Performance Analysis of Three Control Techniques for Buck Converter feeding a Resistive Load

Original Article

Ghulam Mustafa^{1*}, Fiaz Ahmad¹

¹Department of Electrical & Computer Engineering, Air University

*Correspondence: Ghulam Mustafa, gmustafa191672@gmail.com

Citation | A. F. Mustafa. G, “Review on Performance Analysis of Three Control Techniques for Buck Converter feeding a Resistive Load,” Int. J. Innov. Sci. Technol., Special Issue, pp. 39-51, 2022

Received | June 7, 2022; **Revised** | June 23, 2022; **Accepted** | June 28, 2022; **Published** | June 30, 2022.

DOI | <https://doi.org/10.33411/IJIST/2022040504>

In power systems, DC/DC converters are used to reduce or improve the dc voltage level. A dc/dc converter's major difficulty is controlling the output dc voltage closer to the desired set-point voltage at the load and input voltage fluctuation. Designers aim for better efficiency, reduced harmonics, and higher power while keeping converter size and power under safe limits. Several control techniques are used in dc/dc converters to overcome the problems mentioned above. This paper compares the transient performance of three control techniques, namely proportional-integral-derivative (PID) control, fuzzy logic control (FLC), and sliding mode control (SMC) methods, after a brief introduction of these techniques. Secondly, the three techniques have performed simulation results of a buck converter feeding a resistive load. Comparative analyses are presented for various conditions such as input voltage and load variation tests. It is observed that SMC outperforms the other two methods for both simulation scenarios.

Keywords: Buck converter, PID control, Fuzzy logic control (FLC), Sliding mode control (SMC).

Author's Contribution.

All of my co-authors contributed to this research through data collection, write-up, and improvement.

Conflict Of Interest:

The author(s) declare that the publication of this article has no conflict of interest.

Project details.

Nil



Introduction

Nowadays, solar and wind are widely used energy sources for power generation. Through dc/dc or ac/dc converters, the power obtained from these energy sources is regulated. Still, the energy obtained from these sources varies, so continuous output is not achieved from these sources in all situations. Various controlled converters eliminate these issues and achieve the desired voltage output. The design, modeling, and simulation of a dc-dc converter are discussed in [1]. In [2], High voltage dc-dc converter structure topologies, circuit parameter design, system control to improve power flow, and system stability are presented. Output comparison of various forms of the dc-dc converter is discussed in [3].

Control structure, stability, and model of power converters in a dc microgrid are discussed in [4]. In [5], Boost converter efficiency design and simulation improvements are presented using PID control. Different PID controllers are proposed to improve the transient response of dc/dc converters in [6]–[8]. Using a robust PID controller approach, the disturbance rejection problem of the boost converter has been addressed in [9]. In [10], P/PI/PID-based controllers are built for a chopper circuit using coupled inductor in MATLAB/Simulink for smart grid technology.

A fuzzy logic control (FLC) is designed to maintain the output voltage of a buck converter in [11]. In [12], an FLC is designed to enhance the efficiency of a boost converter. The design of a dual-stage double boost converter using FLC is proposed in [13]. A hybrid fuzzy PID control is designed to avoid buck-boost converter output voltage overshoot and oscillations [14]. The efficiency comparison between FLC and PI control of buck converter is presented in [15]. Software and experimental-based buck converter model are designed using FLC in [16] and [17]. Various FLC algorithms for regulating dc/dc converters in solar system applications are presented in [18]–[20].

A boost converter's voltage mode control (VMC) is designed and implemented in [21]. Digital hybrid current mode (HCM) control of a dc/dc converter is designed and implemented in [22]. In [23], two half-bridge dc/dc converters are designed using an average state-space method. A model predictive control (MPC) is designed for a boost converter feeding a constant power load [24].

A sliding mode control (SMC) is proposed to solve the issue of constant power load in a boost converter [25]. In [26], a sliding mode duty-ratio controller (SMDC) is proposed to control the output power of a buck converter. In [27], a modified PWM-based SMC is developed to regulate the output voltage of a boost converter. An SMC of the buck converter is presented for low-power applications in [28]. A robust SMC of a buck converter is designed and tested in [29]. In [30], a second-order SMC is suggested for monitoring the buck converter output voltage. Practical challenges for designing the low-power buck converter using SMC are presented in [31]. Various modifications of SMC to regulate dc/dc converters in industrial applications are proposed in [32]–[35].

This paper's content is divided into different sections: In Section 2, the buck converter model and its modes are presented. Three control techniques of buck converter are defined in Section 3. In Section 4, the simulation results of these control approaches are presented and compared. The conclusion is drawn in Section 5.

The goal of this study is to compare the transient performance of three control techniques of a buck converter. Firstly, a brief overview of three control approaches is presented. Secondly, PID, FLC, and SMC simulation results of a buck converter have been compared and evaluated. Finally, each control technique has been tested to ensure stability, robustness, and dynamic efficiency by changing input voltage/load resistance.

Model of Buck Converter

A buck converter is an electronic control circuit with a lower output voltage than the input voltage. The input voltage (E) and switching duty cycle (u) determine the converter's output voltage (V_o). Buck converter's simple model is illustrated in Figure 1. This converter

contains an inductor (L), a capacitor (C), a transistor (SW), a diode (D), and a load resistor (R).

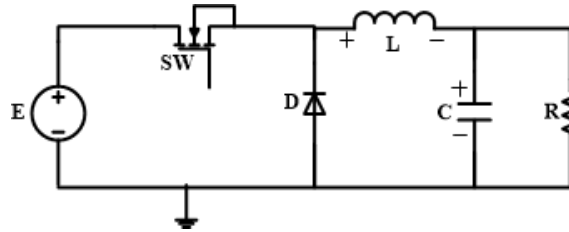

Figure 1. Simple Model of DC/DC buck converter

$$V_o = uE \tag{1}$$

Usually, the buck converter works in two intervals. The first interval occurs when the transistor is switched ON, and the diode is turned OFF (i.e., $u=1$). The circuit for the first interval is shown in Figure 2. For the first interval, equations (2) and (3) are inductor voltage and capacitor current equations.

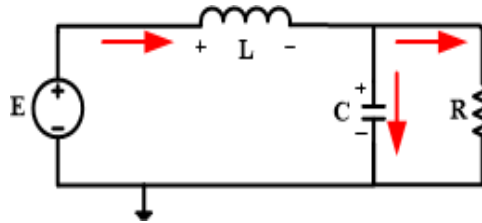

Figure 2. First interval circuit of the buck converter

$$\frac{di_L}{dt} = \frac{E}{L} - \frac{V_o}{L} \tag{2}$$

$$\frac{dV_o}{dt} = \frac{i_L}{C} - \frac{V_o}{RC} \tag{3}$$

Buck converter operated in the second interval when transistor turned OFF, and diode turned ON (i.e., $u=0$), second interval circuit shown in Figure 3. Equations (4) and (5) are inductor voltage and capacitor current equations for the second interval.

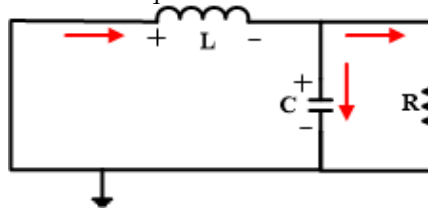

Figure 3. Second interval circuit of the buck converter

$$\frac{di_L}{dt} = -\frac{V_o}{L} \tag{4}$$

$$\frac{dV_o}{dt} = \frac{i_L}{C} - \frac{V_o}{RC} \tag{5}$$

Now, control variable $u(t)$ is defined as;

$$u(t) = \begin{cases} 1 & : \text{Transistor ON, Diode OFF } (u = 1) \\ 0 & : \text{Transistor OFF, Diode ON } (u = 0) \end{cases} \tag{6}$$

After including the control input $u(t)$ From (6), buck converter dynamics equations can be rewritten as given in (7) and (8).

$$\frac{di_L}{dt} = \frac{uE}{L} - \frac{V_o}{L} \tag{7}$$

$$\frac{dVo}{dt} = \frac{i_L}{C} - \frac{Vo}{RC} \tag{8}$$

These equations (7) and (8) identify the buck converter's entire average model.

Material and Methods

Several control techniques have been applied to control the output voltage, current, and switch duty cycle of a buck converter. Voltage mode control (VMC) [21], current-mode control (CMC) [22], state-space average model [23], proportional-integral (PI) [10] and proportional-integral-derivative (PID) [5]-[10] are well-known basic linear control methods. However, in the case of large input voltage and load fluctuations, conventional linear control techniques cannot perform efficiently. So, advanced control techniques address large-signal stability issues in nonlinear systems. Fuzzy logic control (FLC)[10]-[20], model predictive control [24] and sliding mode control (SMC) [25]-[35] are some advanced control methods. In this paper, PID control, FLC and SMC are implemented, and their simulation results are compared.

PID control

A PID controller repeatedly estimates an error value when a difference occurs between the desired reference value and the measured process value. Figure 4 shows a simple model of PID control of buck converter.

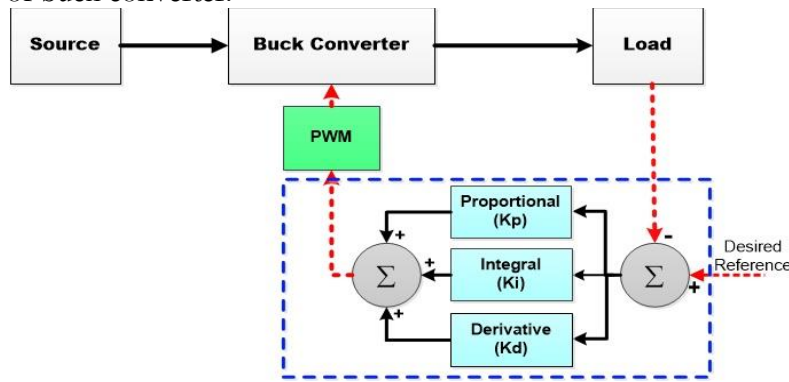

Figure 4. PID control of buck converter

Regarding rising time, settling time, steady-state error, and overshoot, system output performance depends on proportional, derivative, and integral values [7].

The plant's error and the signal equation can be written as;

$$e(t) = V_{ref} - Vo(t) \tag{9}$$

$$w(t) = Kpe(t) + Kd \frac{de(t)}{dt} + Ki \int e(t) dt \tag{10}$$

Where Kp is the proportional gain, Kd is derivative gain, Ki is integral gain, and $e(t)$ is the tracking error which is measured by taking the difference between a reference voltage (V_{ref}) and actual output voltage ($Vo(t)$). If the $w(t)$ A signal is received, and the plant generates a modified output voltage that is matched to the reference voltage again before reaching the goal level [5].

Table 1. Effects of gains in PID closed loop system [5]

	Rising Time	Settling Time	Overshoot	Steady state error
Proportional	Reduce	Minor variation	Rise	Reduce
Integral	Reduce	Rise	Rise	Remove
Derivative	Minor Variation	Reduce	Reduce	Minor Variation

When there is a considerable fluctuation on the source or load side, PID control produces a large overshoot and a long settling period. As a result, advanced control methods such as FLC and SMC are employed to get better outcomes.

Fuzzy Logic Control (FLC)

Fuzzy logic is a valued logic where a real number between 0 and 1 maybe the true value of the variables. Fuzzy logic is based on an "IF-THEN" rules system [15]. The fuzzy controller proposes no accurate mathematical model. Usually, FLC is designed based on general plant information. Figure 5 shows a simple control model of the FLC of a buck converter.

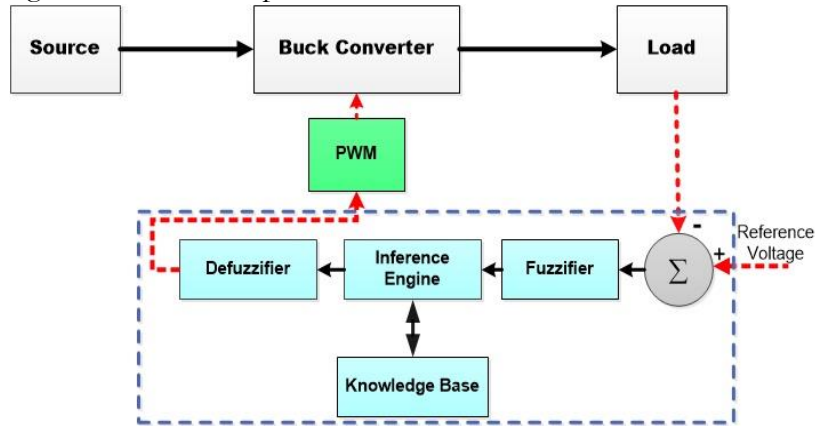

Figure 5. FLC of the buck converter

A fuzzy logic rule system consists of four modules: fuzzification, fuzzy inference, knowledge base, and defuzzification [12]. Fuzzification is a strategy that transforms crisp input data into membership functions [17]. Fuzzy inference is a strategy that is presented to combine membership function with the control rules for controlling fuzzy output [17]. All rules and if-then statements are given in the knowledge base [16]. The defuzzification process is carried out to transform the fuzzy sets to a crisp value [16].

Regulating the output voltage of a buck converter using the fuzzy logic technique requires accurate fuzzy rules and membership functions made on assumptions. To generate fuzzy logic rules,, two inputs error, and change in output voltage error are required. In [12], these two inputs are separated into five categories, which are: negative big (NB), negative small (NS), zero (Z), positive small (PS), and positive big (PB). These fuzzy control rules for error and error change are shown in Table 2.

Table 2. Rules for error and variation of error [12]

$\begin{matrix} (e) \\ (de) \end{matrix}$	NB	NS	Z	PS	PB
NB	NB	NB	NB	NS	Z
NS	NB	NB	NS	Z	PS
Z	NB	NS	Z	PS	PB
PS	NS	Z	PS	PB	PB
PB	Z	PS	PB	PB	PB

FLC surpasses PID control in terms of performance, but it does not provide correct output voltage results when a disturbance occurs at the source/load side. Because fuzzy logic isn't always accurate, decisions are made based on assumptions, so there's no way to know precisely. It's tough to get started with accurate fuzzy rules and membership functions.

Sliding Mode Control (SMC)

Sliding mode control is a variable structure approach that modifies the system behavior by forcing it to slide over a cross-section of its normal behavior using a defined control signal. In SMC, the control law and the sliding surface are two key concepts. Figure 6 shows a simple model of the SMC of the buck converter.

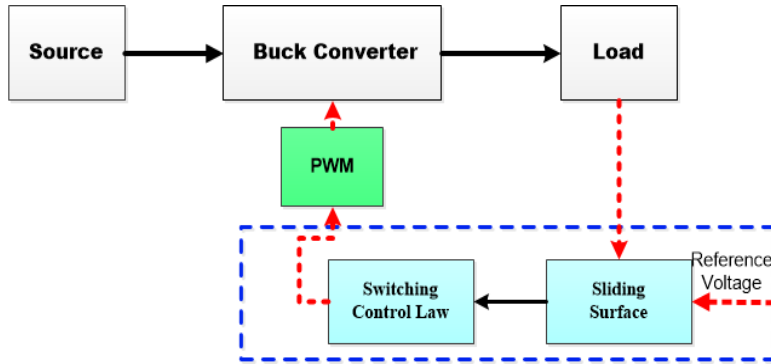

Figure 6. SMC of the buck converter

The switching control law aims to push the plant's state trajectory to a specific (user-identified) surface in the dynamical system and keep it there for a given time interval. A sliding surface is used by the sliding mode controller, which means that the output voltage goes to the wanted value until the system reaches the sliding surface. For designing the sliding function, the system parameters are used. The sliding function is derived from the general sliding mode control principle by a state variable error, defined by a difference in the reference value [29]. Figure 7 shows the behavior of the plane trajectory of SMC.

The system's sliding surface equation is expressed as [29];

$$S = x_1 - x_1^* = 0 \tag{11}$$

Where, x_1 is the output voltage and x_1^* is required output voltage. The corresponding control signal is written as (12).

$$u = \frac{1}{2}(1 - \text{sign}(S)) = \begin{cases} 1. & \text{if } S < 0 \\ 0. & \text{if } S > 0 \end{cases} \tag{12}$$

As the goal is to guarantee that the system's state direction is oriented to the sliding surface $S = 0$ and slides over it, this is achieved using the reaching condition, and stability achieves using the Lyapunov method, which is defined as;

$$\lim_{S \rightarrow 0} S \cdot \dot{S} < 0 \tag{13}$$

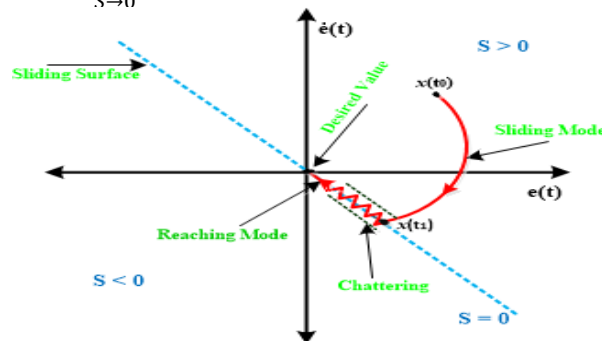

Figure 7. The behavior of the plane trajectory of SMC

Result and discussion

In this section, the simulation results of PID control, FLC, and SMC of the buck converter are discussed and compared. Secondly, two tests have been taken on each control

technique, and their simulation results are compared. Parameters of the buck converter are shown in Table 3.

Table 3. Parameters of the buck converter

S.NO	Description	Parameter	Value
1	Input Voltage	V_{in}	48V
2	Switching Frequency	f_s	25kHz
3	Inductance	L	48mH
4	Capacitance	C	5 μ F
5	Load Resistance	R	100 Ω
6	Reference Voltage	V_{ref}	24V

The simulation outcome of the output voltage of the buck converter using three controls is displayed in Figure 8. PID controller provides a large 15.83% overshoot, low settling time, and does not accurately achieve 24V reference voltage. FLC performs better than PID control but does not achieve reference voltage and produces 23.9V output voltage. FLC reduces overshoot but does not fully remove it. In comparison to previous controls, SMC performed better. It gives a 0.3 % overshoot, fast-rising time and quick settling time. The simulation outcome of the output current of the buck converter using three controls is displayed in Figure 9.

Input voltage variation test

The changed input voltage has compared the robustness, stability, and uncertainty performance of these three control techniques. Firstly, the input voltage reduced from 48 to 45V at 0.01s, then increased from 48 to 51V at 0.03s. Simulation results of the PID controller using the input voltage variation test are presented in Figure 10(a). PID control gives a less robust and highly uncertain output voltage response.

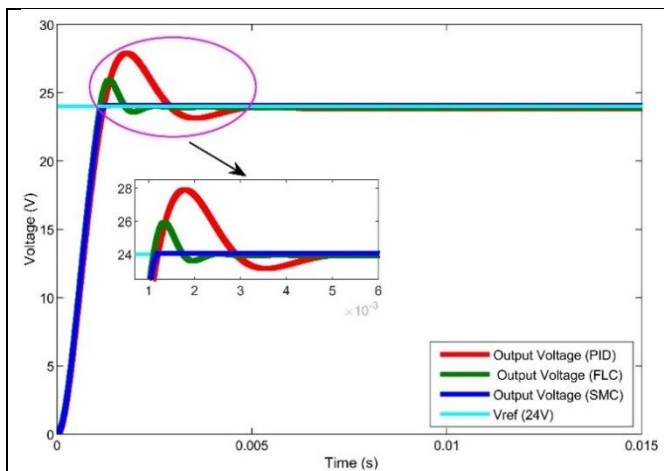

Figure 8. Comparison of buck converter's output voltage using PID control, FLC, and SMC

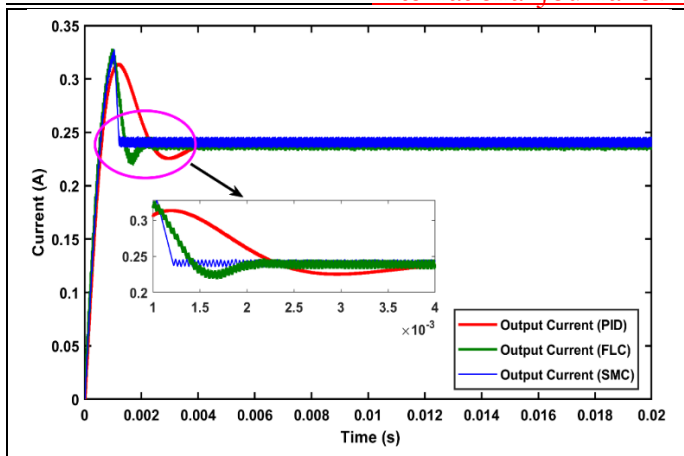

Figure 9. Comparison of buck converter's output current using PID control, FLC, and SMC

Table 4. Performance analysis of control techniques for a buck converter

S.NO	Parameter	PID	FLC	SMC
1	Rise Time (tr)	0.0007s	0.0006s	0.0006s
2	Peak Time (tp)	0.0018s	0.0013s	0.0012s
3	Overshoot	15.83%	4.16%	0.03%
4	Settling Time (ts)	0.0043s	0.0023s	0.0013s
5	Output Voltage (Vo)	23.9V	23.9V	24.06V
6	Output Current (Io)	0.23A	0.24A	0.24A

Simulation results of FLC using the input voltage variation test are presented in Figure 10(b). This technique improved output voltage response with less uncertainty compared to PID control but did not give accuracy. Simulation results of SMC using the input voltage variation test are shown in Figure 10(c). When the input voltage changes, this proposed method has good stability and output voltage response. SMC gives good dynamic performance and very small fluctuations compared to previous controls.

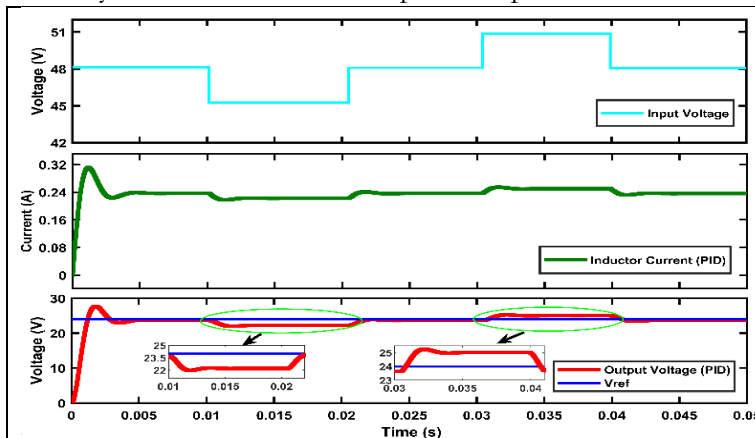

Figure 10(a). Input voltage variation simulation results of PID control

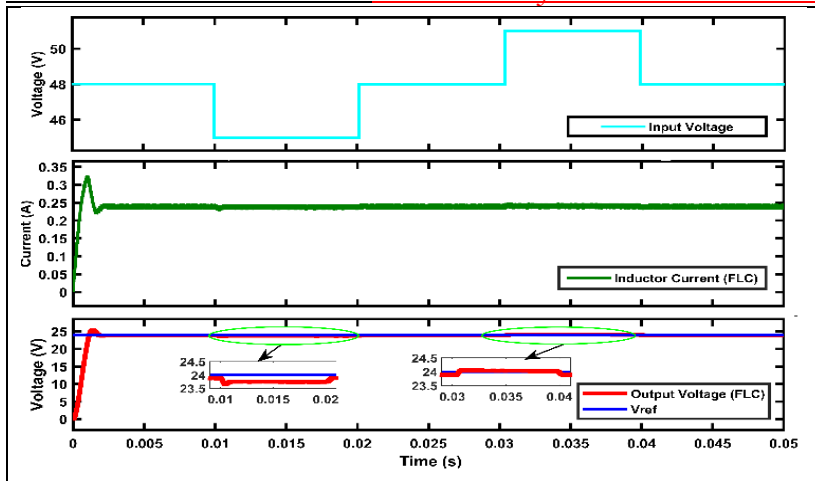

Figure 10(b). Input voltage variation simulation results of FLC

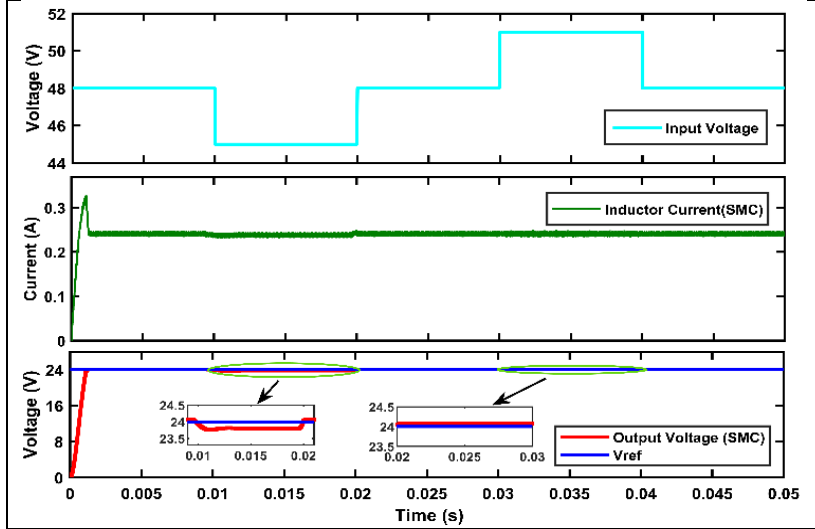

Figure 10(c). Input voltage variation simulation results of SMC

Load variation test

In the load variation test, Firstly, the load resistance is reduced from 100Ω to 50Ω at 0.01s, then increased from 50Ω to 100Ω at 0.02s. At 0.03s, the load resistance is increased from 100Ω to 200Ω, then decreased to 100Ω at 0.04s. Simulation results of PID control using the load variation test are presented in Figure 11(a). The proposed method shows that when 50Ω load resistance is connected, the inductor current goes to 0.46A, and the output voltage goes to 16V. When 200Ω load resistance is connected, the inductor current goes to 0.08A, and the output voltage goes to 31V. It shows less robustness and large output voltage oscillations.

Simulation results of FLC using the load variation test are presented in Figure 11 (b). The proposed method shows that when 50Ω load resistance is connected, the inductor current goes to 0.45A, and the output voltage goes to 16V. When 200Ω load resistance is connected, the inductor current goes to 0.12A, and the output voltage goes to 26.5V. It shows better robustness and fewer fluctuations than PID control, but stability is not achieved when load resistance increases from 50 to 100Ω.

Simulation results of SMC using load variation test are presented in Figure 11 (c). The proposed method shows that when 50Ω load resistance is connected, the inductor current goes to 0.35A, and the output voltage goes to 18V. When 200Ω load resistance is connected, then the inductor current goes to 0.1A, and the output voltage goes to 25V. It shows good stability and small oscillations and gives a better output voltage response compared to previous controls.

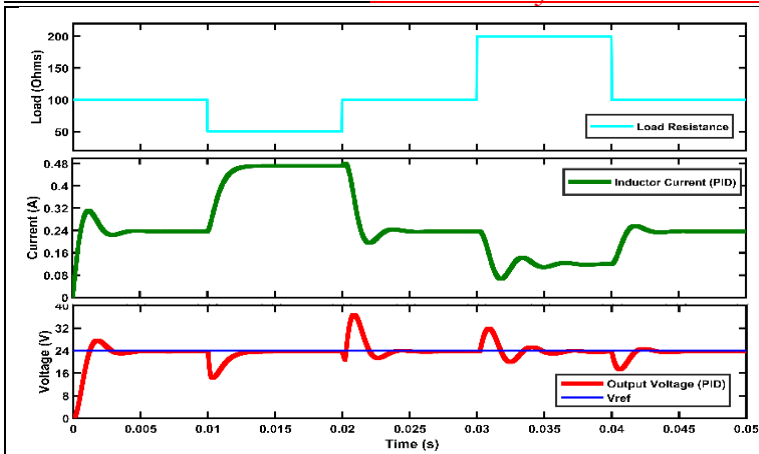

Figure 11(a). Simulation results of PID control using load variation test

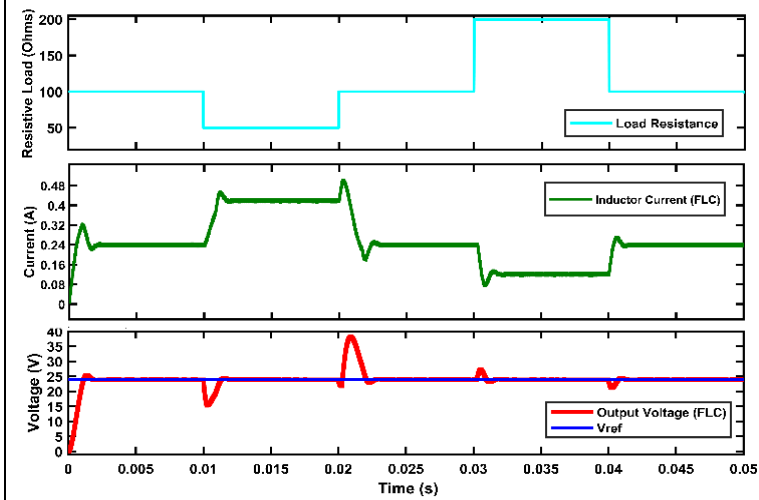

Figure 11(b). Simulation results of FLC using load variation test

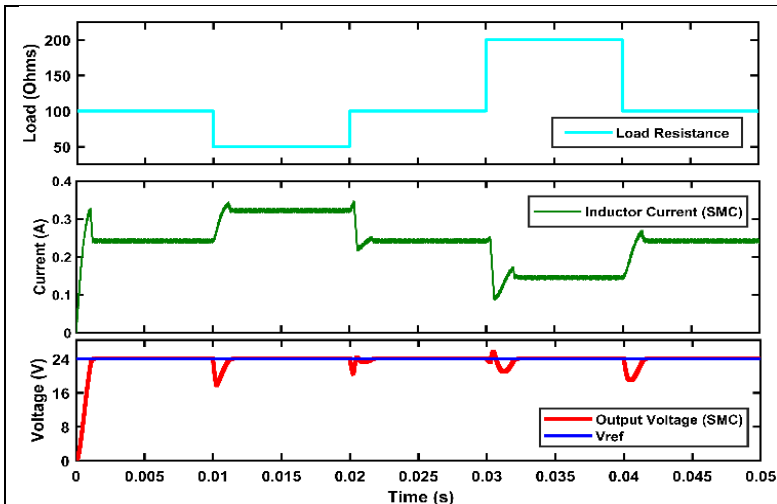

Figure 11(c). Simulation results of SMC using load variation test

Table 5. Comparison of control techniques for a buck converter

Control Method	Advantage	Disadvantage
PID	<ul style="list-style-type: none"> - It is simple and easy to implement - Easy to understand - Reliable for Linear systems - Easy to tune by the method of trial and error 	<ul style="list-style-type: none"> - It is efficient for nonlinear systems with a restricted operating range - As output voltage overshoot decreases, it shows a longer rise time - Processes take a long time and give poor performance
FLC	<ul style="list-style-type: none"> - Quickly modified by adding new rules to increase performance - Simple and easy to understand - Give better performance compare to PID Control 	<ul style="list-style-type: none"> - Fuzzy logic isn't always correct, decisions are based on assumptions, so there's no way to know exactly - Practical design is a challenge - It's difficult, to begin with, accurate fuzzy rules and membership functions
SMC	<ul style="list-style-type: none"> - Fast and robust dynamic Response - Finite-time convergence - Large signal stability 	<ul style="list-style-type: none"> - Chattering problem (the undesirable phenomenon of oscillations having finite frequency and amplitude) - Uncertainty bounds (limits) and external disturbances must be known

Conclusion

This paper has investigated the overall performance of three different control approaches to maintain the output voltage of a buck converter. From simulation results, SMC performed better during input voltage/load variations tests than other methods in terms of stability, robustness, and dynamic efficiency. There is still potential for more accurate and effective control methods to be designed. SMC has a chattering problem (an undesirable phenomenon of oscillations having finite frequency and amplitude). In the future, adaptive control and disturbance/observer-based estimation techniques have been used with SMC to resolve the problem of chattering and designed adaptive control law which changed according to disturbance and improved robustness and accuracy of converter' output when a disturbance occurs.

References

- [1] S. Chander, P. Agarwal, and I. Gupta, "Design, modeling and simulation of DC-DC converter," *2010 9th Int. Power Energy Conf. IPEC 2010*, pp. 456–461, 2010, doi: 10.1109/IPECON.2010.5697039.
- [2] R. Wang, H. Chen, T. Lei, and Y. Shi, "Research on DC-DC converter with high voltage and high power," *2014 IEEE Int. Conf. Inf. Autom. ICI A 2014*, pp. 323–326, Oct. 2014, doi: 10.1109/ICINFA.2014.6932675.
- [3] A. Lindiya, S. Palani, and M. Iyyappan, "Performance Comparison of Various Controllers for DC-DC Synchronous Buck Converter," *Procedia Eng.*, vol. 38, pp. 2679–2693, Jan. 2012, doi: 10.1016/J.PROENG.2012.06.315.
- [4] S. Dahale, A. Das, N. M. Pindoriya, and S. Rajendran, "An overview of DC-DC converter topologies and controls in DC microgrid," *2017 7th Int. Conf. Power Syst. ICPS 2017*, pp. 410–415, Jun. 2018, doi: 10.1109/ICPES.2017.8387329.
- [5] Mirza Fuad Adnan, Mohammad Abdul Moin Oninda, Mirza Muntasir Nishat, and Naful Islam, "Design and Simulation of a DC - DC Boost Converter with PID Controller for Enhanced Performance," *Int. J. Eng. Res.*, vol. V6, no. 09, 2017, doi: 10.17577/ijertv6is090029.
- [6] S. W. Seo and H. H. Choi, "Digital implementation of fractional order PID-Type controller for boost DC-DC converter," *IEEE Access*, vol. 7, pp. 142652–142662, 2019, doi:

- 10.1109/ACCESS.2019.2945065.
- [7] S. Satpathy, S. Ghosh, S. Das, S. Debbarma, and B. K. Bhattacharyya, "Study of Dynamic response of DC-DC buck converter Based On PID controller," *Proc. ICCIoT 2018*, no. March, pp. 806–810, 2019.
- [8] H. A. H. Ammar Falah Algamluoli, "Voltage Controller of DC-DC Buck Boost Converter with Proposed PID Controller," *Int. J. Adv. Res. Comput. Eng. Technol.*, vol. 9, no. 1, pp. 1–4, 2020.
- [9] T. Kobaku, R. Jeyasenthil, S. Sahoo, and T. Dragicevic, "Experimental Verification of Robust PID Controller under Feedforward Framework for a Nonminimum Phase DC-DC Boost Converter," *IEEE J. Emerg. Sel. Top. Power Electron.*, vol. 9, no. 3, pp. 3373–3383, Jun. 2021, doi: 10.1109/JESTPE.2020.2999649.
- [10] S. P. Sunddararaj, S. S. Rangarajan, U. Subramaniam, E. R. Collins, and T. Senjyu, "Performance of p/pi/pid based controller in dc-dc converter for pv applications and smart grid technology," *Proc. 7th Int. Conf. Electr. Energy Syst. ICEES 2021*, pp. 171–176, Feb. 2021, doi: 10.1109/ICEES51510.2021.9383671.
- [11] M. K. Al-Nussairi, R. Bayindir, and E. Hossain, "Fuzzy logic controller for Dc-Dc buck converter with constant power load," pp. 1175–1179, Dec. 2017, doi: 10.1109/ICRERA.2017.8191239.
- [12] N. F. Nik Ismail, I. Musirin, R. Baharom, and D. Johari, "Fuzzy logic controller on DC/DC boost converter," *PECon2010 - 2010 IEEE Int. Conf. Power Energy*, pp. 661–666, 2010, doi: 10.1109/PECON.2010.5697663.
- [13] F. Logic, "Properties & Relationships F UZZY L OGIC & F UZZY S YSTEMS F UZZY L OGIC & F UZZY S YSTEMS," vol. 2, no. 1, pp. 1–44, 2011.
- [14] K. F. Hussein, I. Abdel-Qader, and M. K. Hussain, "Hybrid fuzzy PID controller for buck-boost converter in solar energy-battery systems," *IEEE Int. Conf. Electro Inf. Technol.*, vol. 2015-June, pp. 70–75, Jun. 2015, doi: 10.1109/EIT.2015.7293323.
- [15] S. Maity *et al.*, "Performance analysis of fuzzy logic controlled DC-DC converters," *Proc. 2019 IEEE Int. Conf. Commun. Signal Process. ICCSP 2019*, pp. 165–171, Apr. 2019, doi: 10.1109/ICCSP.2019.8698113.
- [16] K. Swathy, S. Jantre, Y. Jadhav, S. M. Labde, and P. Kadam, "Design and Hardware Implementation of Closed Loop Buck Converter Using Fuzzy Logic Controller," *Proc. 2nd Int. Conf. Electron. Commun. Aerosp. Technol. ICECA 2018*, pp. 175–180, Sep. 2018, doi: 10.1109/ICECA.2018.8474570.
- [17] T. U. Hassan *et al.*, "A Novel Algorithm for MPPT of an Isolated PV System Using Push Pull Converter with Fuzzy Logic Controller," *Energies 2020, Vol. 13, Page 4007*, vol. 13, no. 15, p. 4007, Aug. 2020, doi: 10.3390/EN13154007.
- [18] N. D. Bhat, D. B. Kanse, S. D. Patil, and S. D. Pawar, "DC/DC Buck Converter Using Fuzzy Logic Controller," pp. 182–187, Jul. 2020, doi: 10.1109/ICES48766.2020.9138084.
- [19] A. Bharathi Sankar Ammayappan and R. Seyezhai, "Implementation of fuzzy logic control based mppt for photovoltaic system with silicon carbide (Sic) boost dc-dc converter," *WSEAS Trans. Syst. Control*, vol. 16, pp. 198–215, 2021, doi: 10.37394/23203.2021.16.17.
- [20] T. Sutikno, A. C. Subrata, and A. Elkhateb, "Evaluation of Fuzzy Membership Function Effects for Maximum Power Point Tracking Technique of Photovoltaic System," *IEEE Access*, vol. 9, pp. 109157–109165, 2021, doi: 10.1109/ACCESS.2021.3102050.
- [21] H. Al-Baidhani, M. K. Kazimierczuk, and A. Reatti, "Nonlinear Modeling and Voltage-Mode Control of DC-DC Boost Converter for CCM," *Proc. - IEEE Int. Symp. Circuits Syst.*, vol. 2018-May, Apr. 2018, doi: 10.1109/ISCAS.2018.8351078.
- [22] A. Ugur and M. Yilmaz, "Digital hybrid current mode control for DC–DC converters," *IET Power Electron.*, vol. 12, no. 4, pp. 891–898, Apr. 2019, doi: 10.1049/IET-PEL.2018.6035.
- [23] M. S. M. Sarif, T. X. Pei, and A. Z. Annuar, "Modeling, design and control of bidirectional DC-DC converter using state-space average model," *ISCAIE 2018 - 2018 IEEE Symp. Comput. Appl. Ind. Electron.*, pp. 416–421, Jul. 2018, doi: 10.1109/ISCAIE.2018.8405509.
- [24] Z. Karami, Q. Shafiee, S. Sahoo, M. Yaribeygi, H. Bevrani, and T. Dragicevic, "Hybrid Model Predictive Control of DC-DC Boost Converters with Constant Power Load," *IEEE Trans.*

- Energy Convers.*, vol. 36, no. 2, pp. 1347–1356, Jun. 2021, doi: 10.1109/TEC.2020.3047754.
- [25] B. A. Martínez-Treviño, A. El Aroudi, E. Vidal-Idiarte, A. Cid-Pastor, and L. Martínez-Salamero, "Sliding-mode control of a boost converter under constant power loading conditions," *IET Power Electron.*, vol. 12, no. 3, pp. 521–529, Mar. 2019, doi: 10.1049/IET-PEL.2018.5098.
- [26] Y. Zhao, W. Qiao, and D. Ha, "A sliding-mode duty-ratio controller for DC/DC buck converters with constant power loads," *IEEE Trans. Ind. Appl.*, vol. 50, no. 2, pp. 1448–1458, 2014, doi: 10.1109/TIA.2013.2273751.
- [27] S. H. Chincholkar, W. Jiang, and C. Y. Chan, "An Improved PWM-Based Sliding-Mode Controller for a DC-DC Cascade Boost Converter," *IEEE Trans. Circuits Syst. II Express Briefs*, vol. 65, no. 11, pp. 1639–1643, Nov. 2018, doi: 10.1109/TCSII.2017.2754292.
- [28] N. Kiran, "Sliding Mode Control of Buck Converter," *Bull. Electr. Eng. Informatics*, vol. 3, no. 1, 2014, doi: 10.12928/eei.v3i1.183.
- [29] H. Guldemir, "Study of Sliding Mode Control of DC-DC Buck Converter," *Energy Power Eng.*, vol. 03, no. 04, pp. 401–406, 2011, doi: 10.4236/epe.2011.34051.
- [30] S. Ding, W. X. Zheng, J. Sun, and J. Wang, "Second-order sliding-mode controller design and its implementation for buck converters," *IEEE Trans. Ind. Informatics*, vol. 14, no. 5, pp. 1990–2000, May 2018, doi: 10.1109/TII.2017.2758263.
- [31] S. Huerta-Moro, J. I. Trujillo-Flores, J. C. Villegas-Hernandez, A. M. Rodriguez-Dominguez, J. F. Guerrero-Castellanos, and V. R. Gonzalez-Diaz, "A simple sliding-mode control circuit for buck DC-DC converters," *2019 28th Int. Fall Meet. Commun. Comput. ROC C 2019 - Proc.*, pp. 24–27, Mar. 2019, doi: 10.1109/ROCC.2019.8873540.
- [32] A. Alzawaideh and I. Boiko, "Analysis of a Sliding Mode DC-DC Boost Converter through LPRS of a Nonlinear Plant," *IEEE Trans. Power Electron.*, vol. 35, no. 11, pp. 12321–12331, Nov. 2020, doi: 10.1109/TPEL.2020.2983596.
- [33] Z. Wang, S. Li, and Q. Li, "Discrete-Time Fast Terminal Sliding Mode Control Design for DC-DC Buck Converters with Mismatched Disturbances," *IEEE Trans. Ind. Informatics*, vol. 16, no. 2, pp. 1204–1213, Feb. 2020, doi: 10.1109/TII.2019.2937878.
- [34] X. Lin, J. Liu, F. Liu, Z. Liu, Y. Gao, and G. Sun, "Fractional-order sliding mode approach of buck converters with mismatched disturbances," *IEEE Trans. Circuits Syst. I Regul. Pap.*, vol. 68, no. 9, pp. 3890–3900, Sep. 2021, doi: 10.1109/TCSI.2021.3092138.
- [35] H. Al-Baidhani, T. Salvatierra, R. Ordonez, and M. K. Kazimierczuk, "Simplified Nonlinear Voltage-Mode Control of PWM DC-DC Buck Converter," *IEEE Trans. Energy Convers.*, vol. 36, no. 1, pp. 431–440, Mar. 2021, doi: 10.1109/TEC.2020.3007739.



Copyright © by authors and 50Sea. This work is licensed under Creative Commons Attribution 4.0 International License.